



**Manuale d'installazione**  
*Installation Manual*

**WELLNESS**  
**SERIES**  
**Brass**



**Colonna doccia esterna  
da parete completa  
(Doccetta tonda, Soffione tondo)**

*Exposed shower group  
(round Head Shower,  
round Hand Shower)*

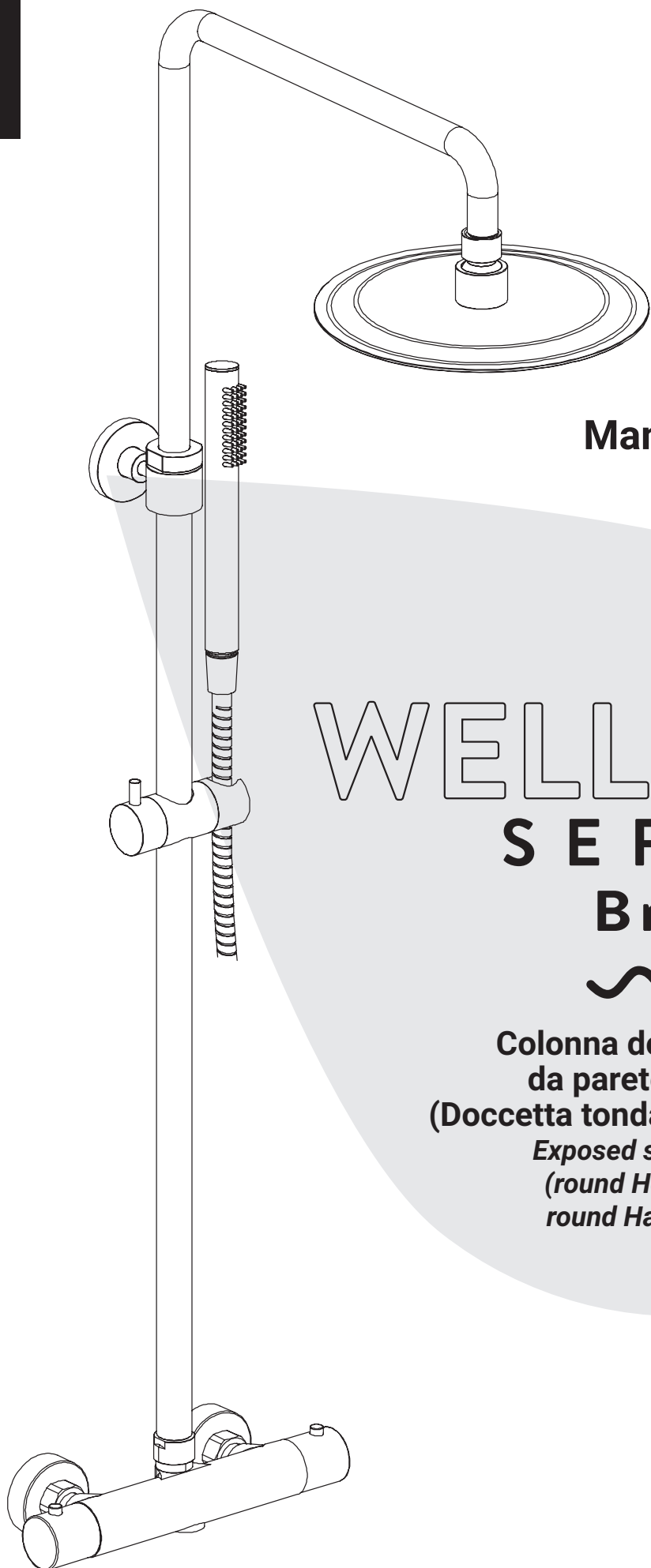



## Indice

### Index

Dimensioni <i>Dimensions</i> .....	pag. 3
Ricambi <i>Spare parts</i> .....	pag. 4
Installazione <i>Installation</i> .....	pag. 5/7
Portate <i>Flows</i> .....	pag. 8/9
Manutenzione Generale <i>General Maintenance</i> .....	pag. 10

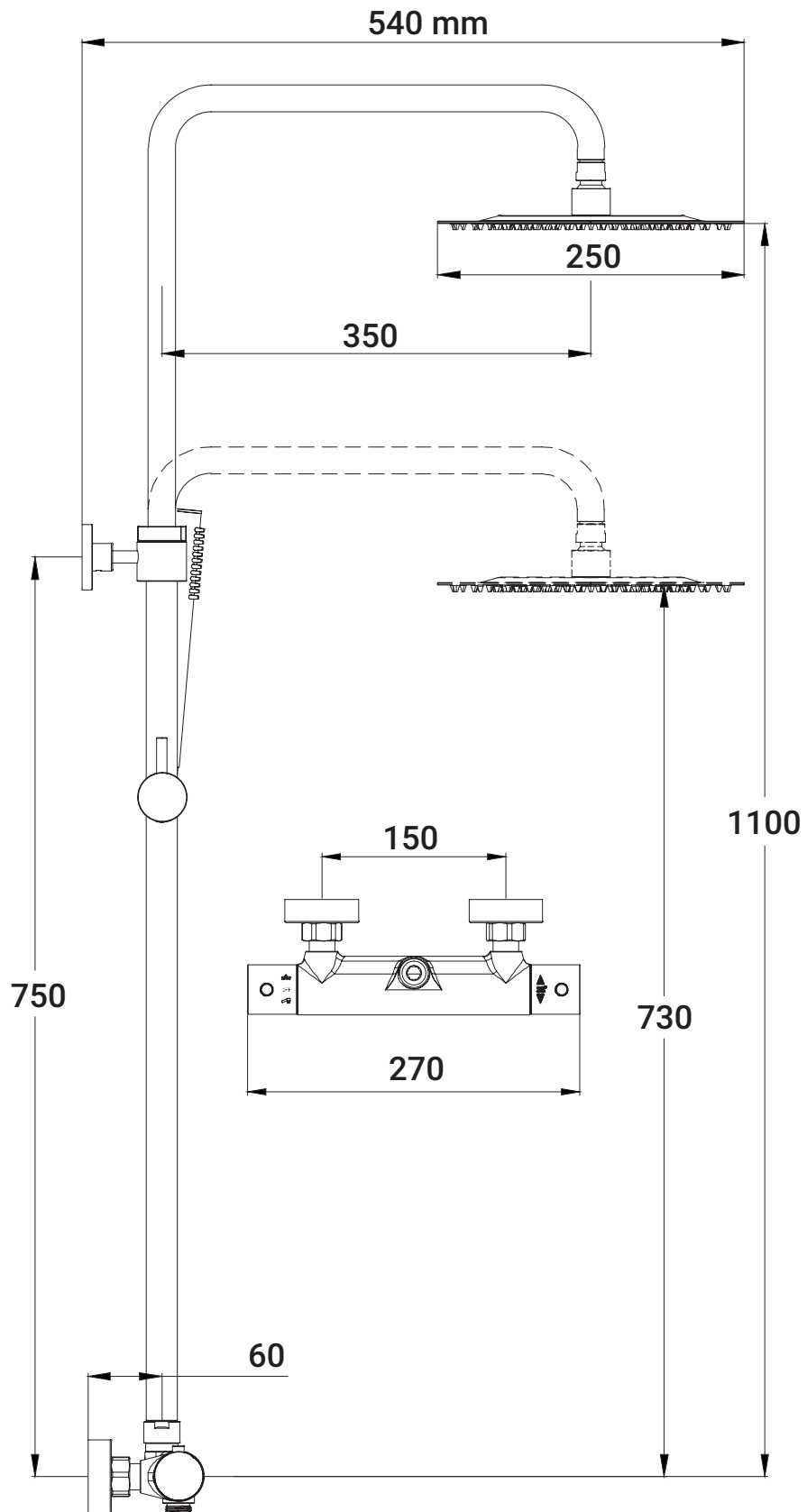

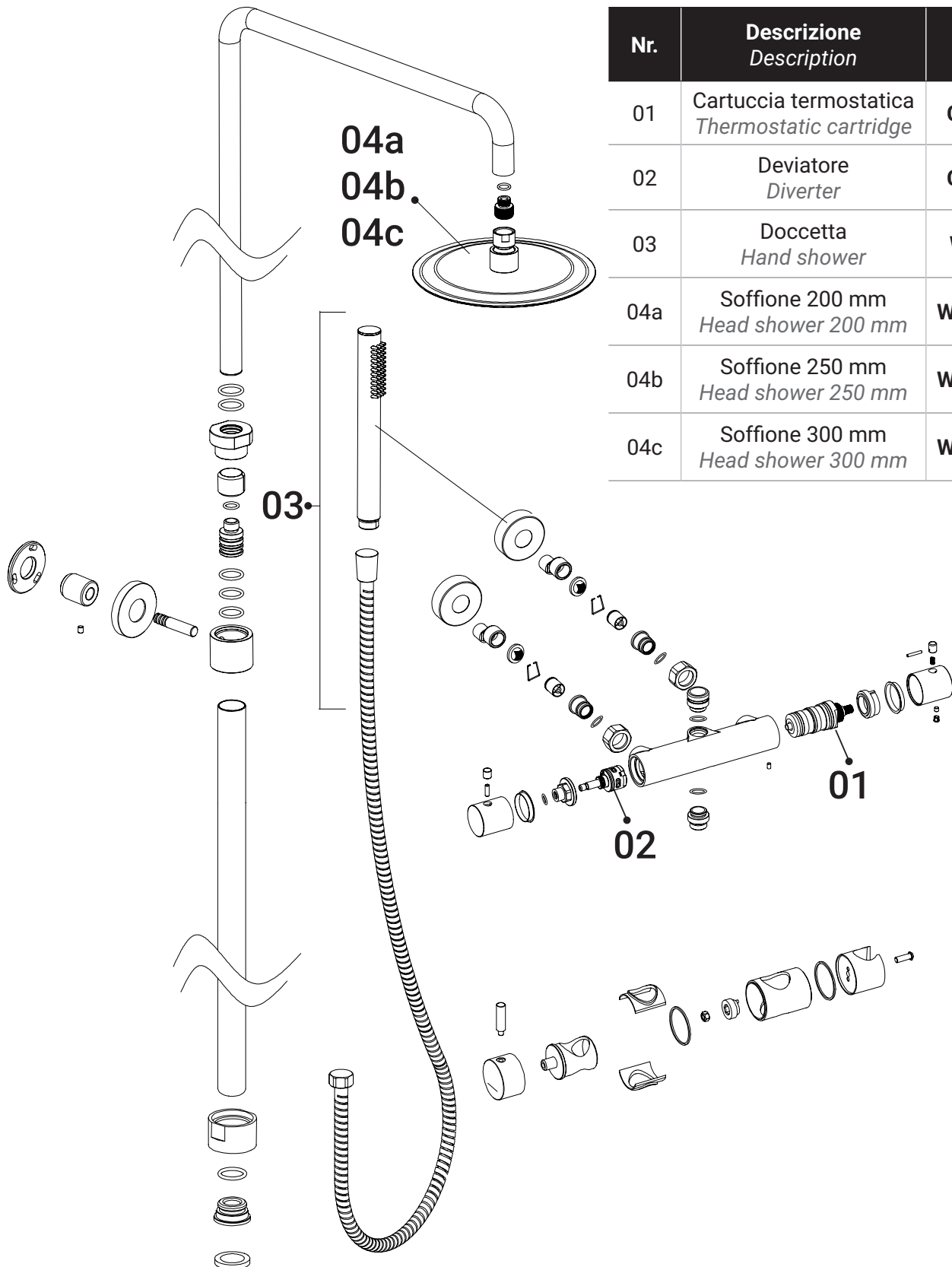

Nr.	Descrizione Description	Codice Code
01	Cartuccia termostatica Thermostatic cartridge	CA0010
02	Deviatore Diverter	CA0011
03	Doccetta Hand shower	WBDC
04a	Soffione 200 mm Head shower 200 mm	WBST20C
04b	Soffione 250 mm Head shower 250 mm	WBST25C
04c	Soffione 300 mm Head shower 300 mm	WBST30C

**Prima dell'installazione**  
*Before Installation*

Rimuovi tutto il contenuto dalla confezione e verificane la completezza.

*Remove all contents from the package and check for completeness.*

**Strumenti necessari**  
*Tools you need*

Cacciavite  
*Cross screwdriver*

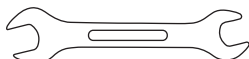

Chiave inglese  
*Wrench*

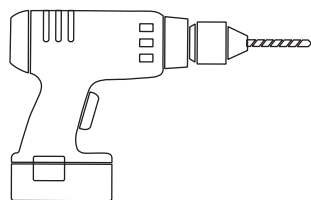

Trapano  
*Drill*



Nastro di teflon  
*Teflon Tape*

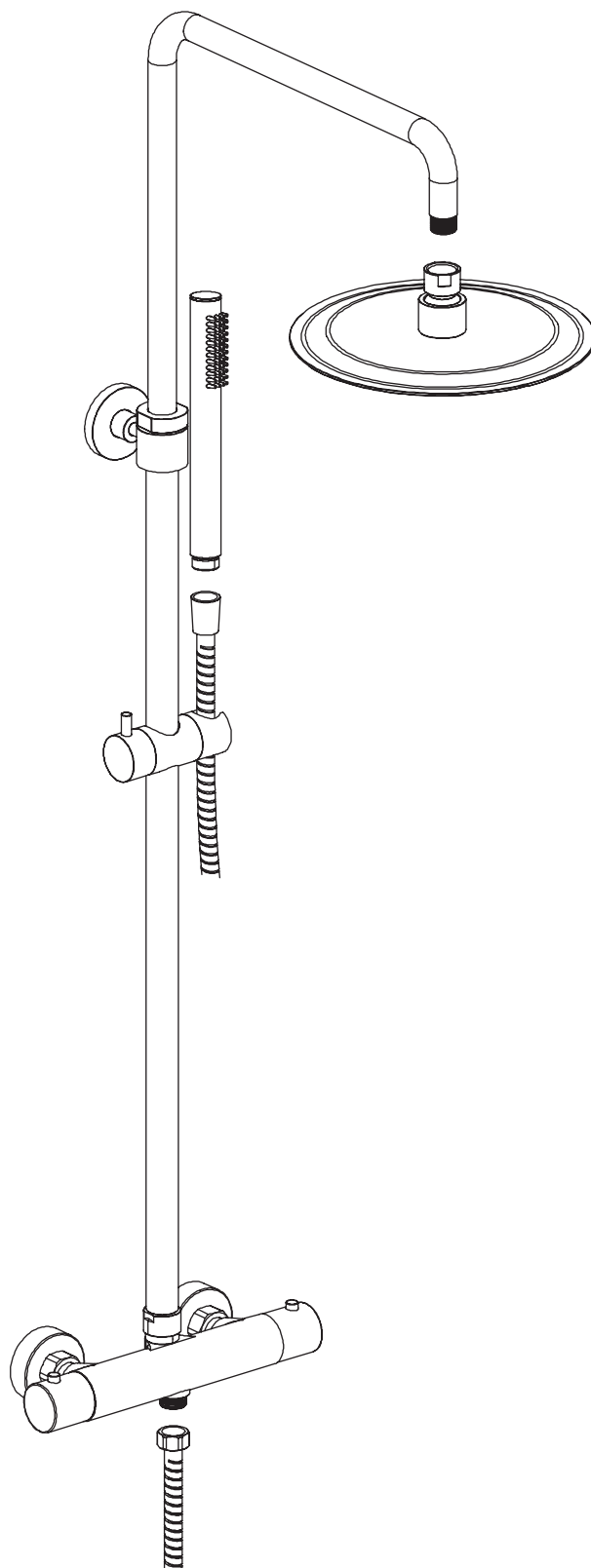



### STEP 1

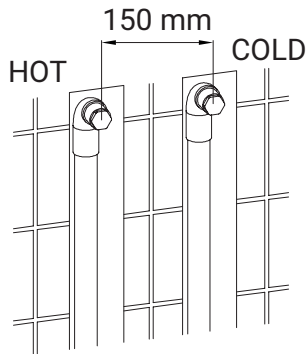

### STEP 2

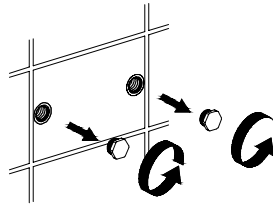

### STEP 3

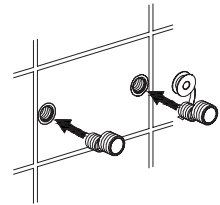

### STEP 4

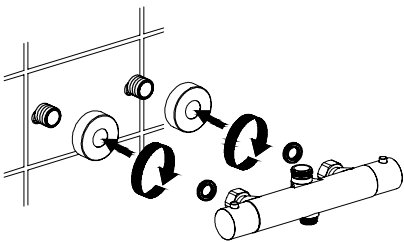

### STEP 5

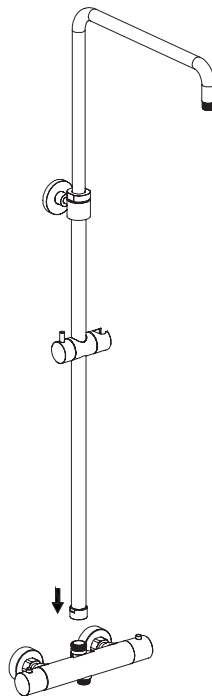

### STEP 6

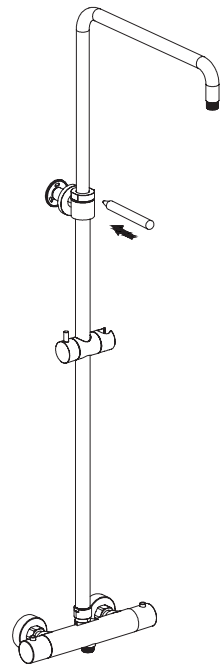



STEP 7

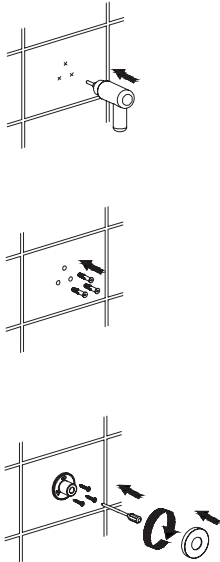

STEP 8

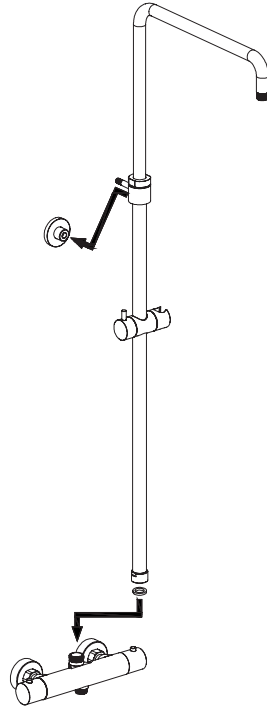

STEP 9

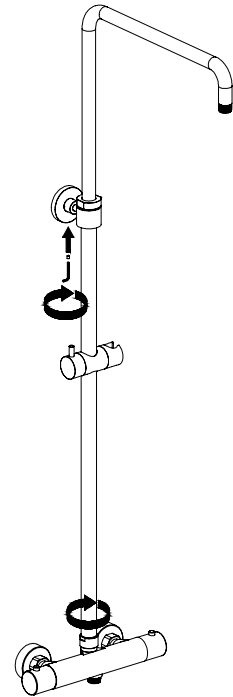

STEP 10

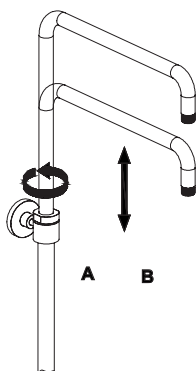

STEP 11

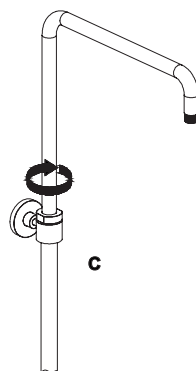

STEP 12

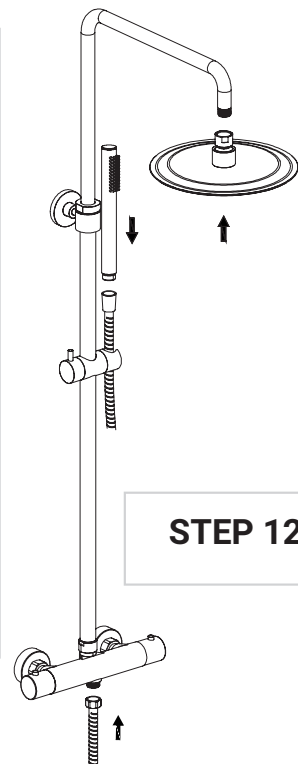



Misurazione (Measure)	Pressione (Pressure) (bar)	Portata Soffione (posizione 38° C) (Hot Head Shower Flow Rate) (l/min)
1	0	0,00
2	0,5	6,68
3	1	7,93
4	1,5	9,69
5	2	11,18
6	2,5	12,53
7	3	13,57
8	3,5	14,62
9	4	15,66
10	4,5	16,47
11	5	17,42
12	5,5	18,35
13	6	19,10

**Massima Pressione Operativa (MPO): 5 bar**

*Maximum Operating Pressure (MOP): 5 bar*

**Test eseguito con connessioni originali**

*(Test performed with original connections)*

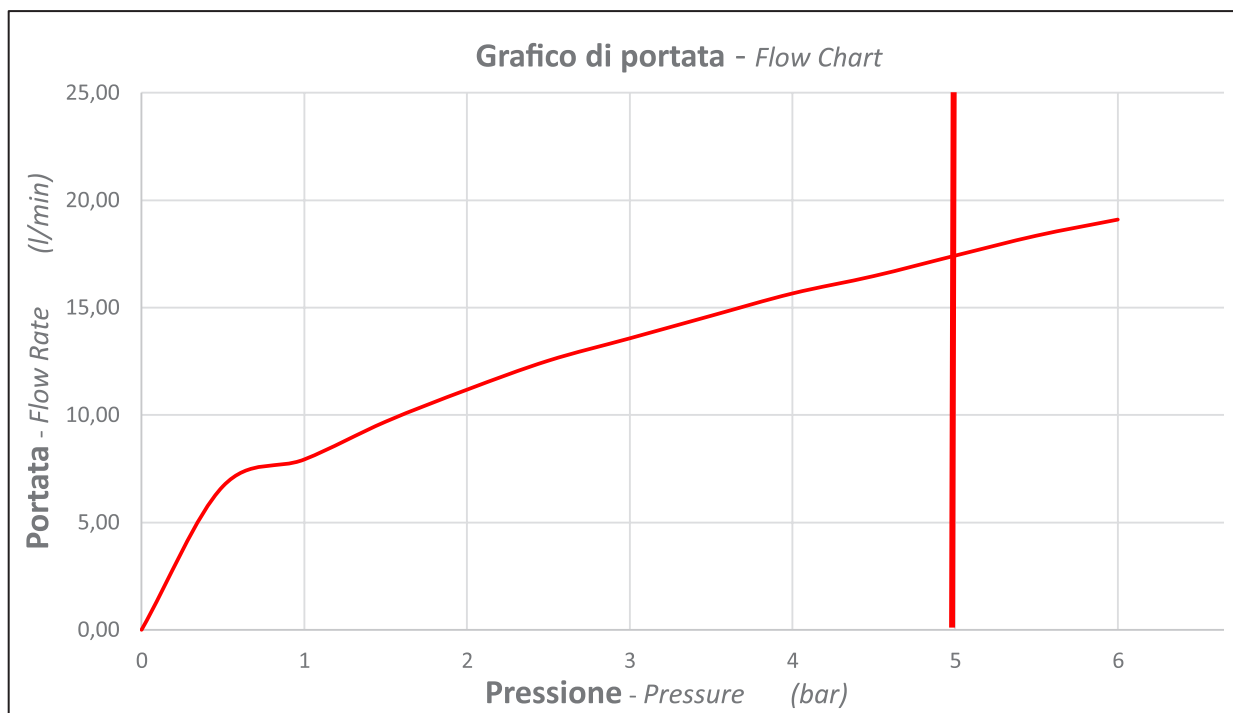

**Non superare la pressione di 5 bar (linea rossa)**

*Do not exceed the pressure of 5 bar (red line)*



Misurazione (Measure)	Pressione (Pressure) (bar)	Portata Doccetta (posizione 38° C) (Hot Hand Shower Flow Rate) (l/min)
1	0	0,00
2	0,5	5,01
3	1	6,10
4	1,5	7,35
5	2	8,39
6	2,5	9,66
7	3	10,59
8	3,5	11,37
9	4	12,44
10	4,5	13,14
11	5	14,21
12	5,5	14,67
13	6	15,54

**Massima Pressione Operativa (MPO): 5 bar**  
Maximum Operating Pressure (MOP): 5 bar

**Test eseguito con connessioni originali**  
(Test performed with original connections)

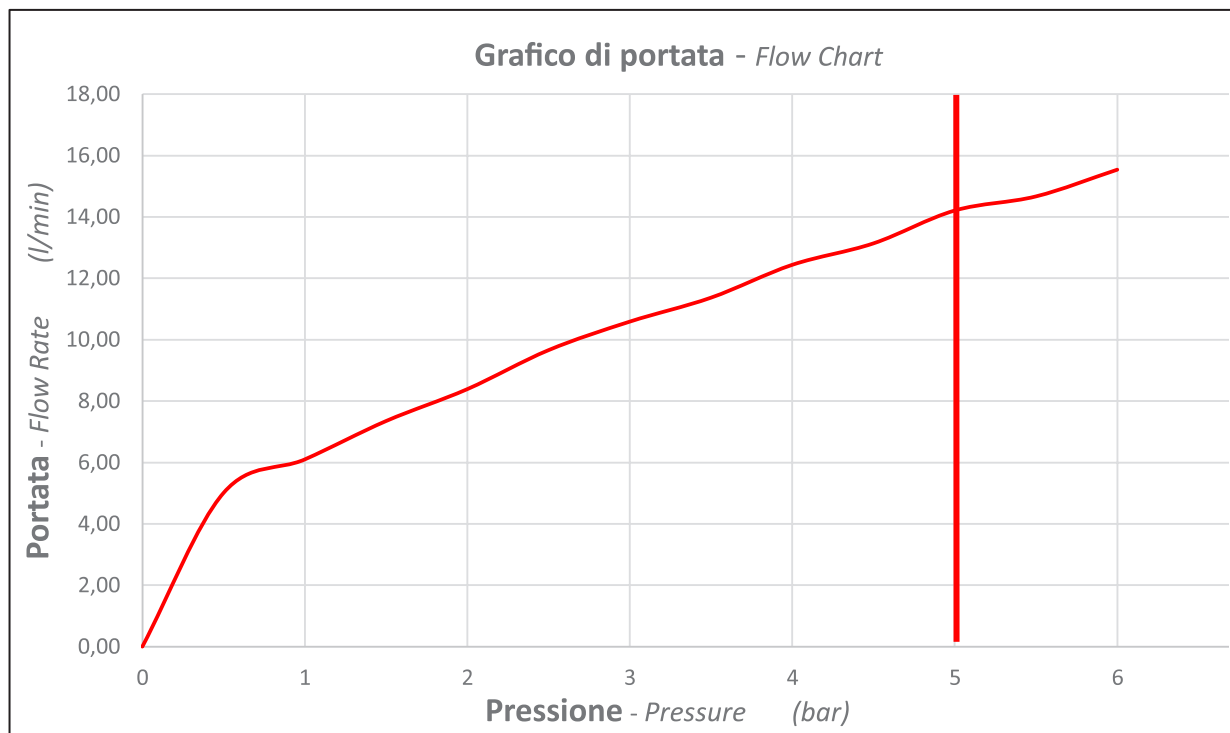

**Non superare la pressione di 5 bar (linea rossa)**  
Do not exceed the pressure of 5 bar (red line)



Non utilizzare, per la pulizia, in nessun caso acidi, solventi, candeggina, ammoniaca o prodotti contenenti acidi e spugne o spazzole con effetto abrasivo.

*Never use acids, solvents, bleach, ammonia or products containing acids and sponges or brushes with an abrasive effect for cleaning.*

---



Per un corretto mantenimento dei prodotti si consiglia una pulizia periodica attraverso detergenti neutri o acqua e sapone.

*For correct maintenance of the products, periodic cleaning is recommended using neutral detergents or soap and water.*

---



Per evitare la formazione di depositi calcarei sciacquare sempre le superfici dopo lavaggio con abbondante acqua e asciugare accuratamente con un panno morbido.

*To avoid the formation of limescale deposits, always rinse the surfaces after washing with plenty of water and dry carefully with a soft cloth.*