

Manuale d'installazione
Installation Manual

SAKURA

SERIES



Lavabo Miscelatore Monocomando
Basin Single Lever Mixer

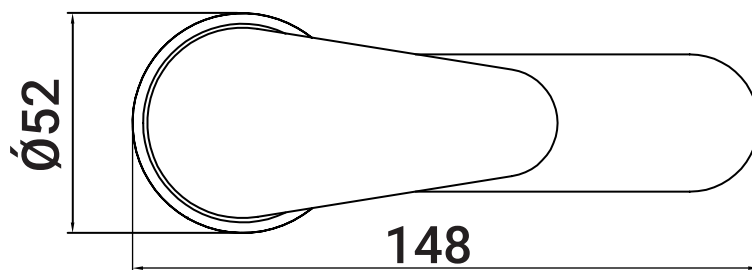
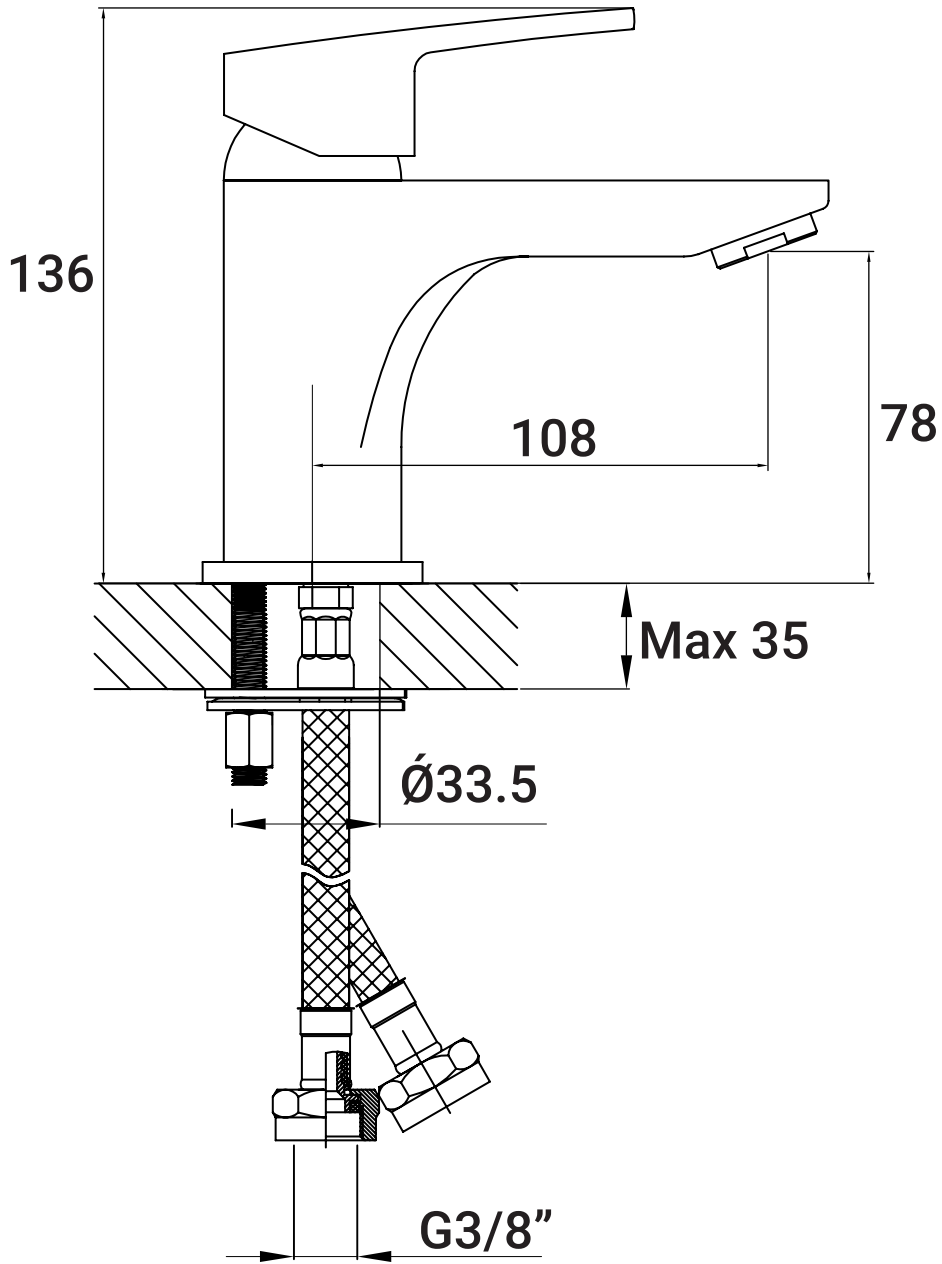



| Nr. | Descrizione Description | Codice Code |
|-----|---------------------------------------|----------------|
| 01 | Cartuccia Cartridge | CA0008 |
| 02 | Aeratore limitato Limited Aerator | AL0004 |
| 02a | Aeratore standard Standard Aerator | AR0004 |
| 03 | Flessibili Hoses | FL0002 |
| 04 | Kit fissaggio Fixing kit | FIX0005 |

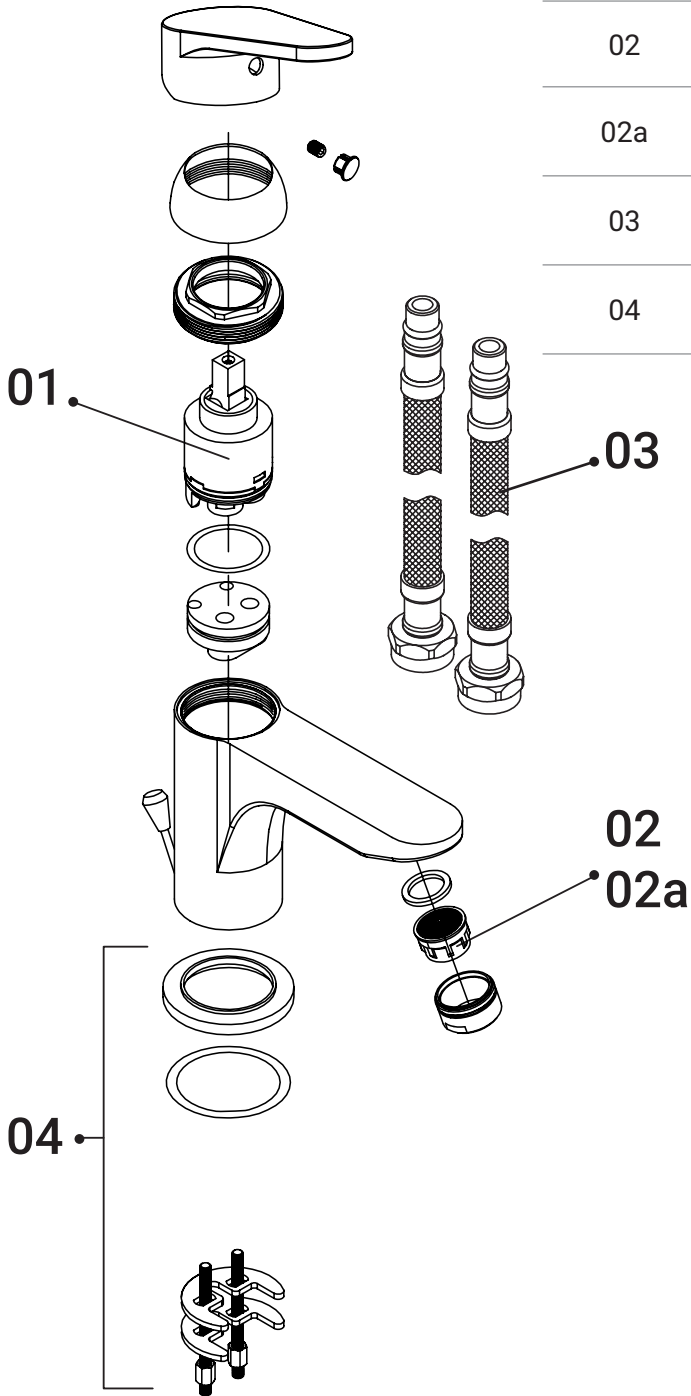



Prima dell'installazione Before Installation



Rimuovi tutto il contenuto dalla confezione e verificane la completezza.

Remove all contents from the package and check for completeness.

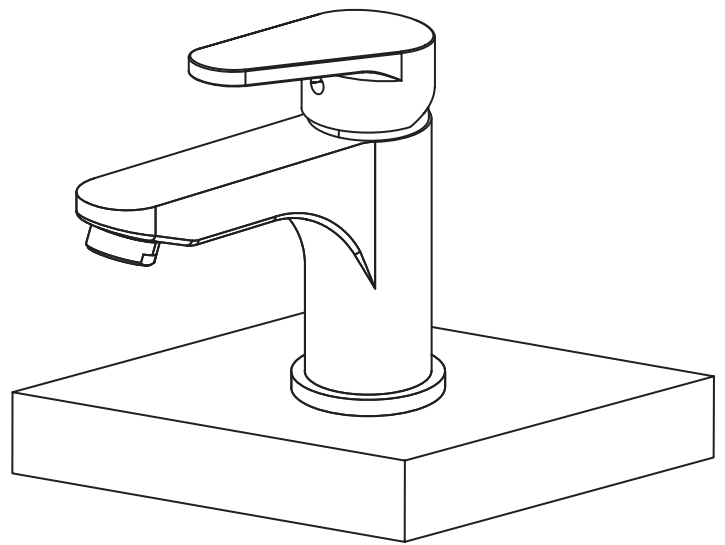

Strumenti necessari Tools you need

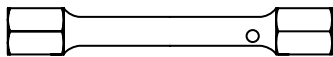

Chiave a tubo
Pipe wrench



Nastro di teflon
Teflon Tape

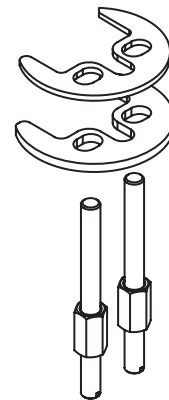



STEP 1

Tagliare un foro di montaggio da 35 mm (1-3/8") di diametro nella posizione desiderata.

Cut a mounting hole 35mm (1-3/8") in diameter in the desired position.

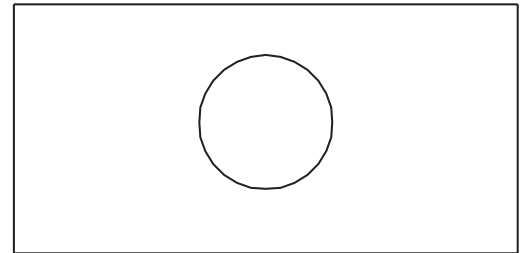
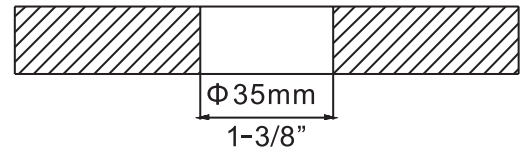

STEP 2

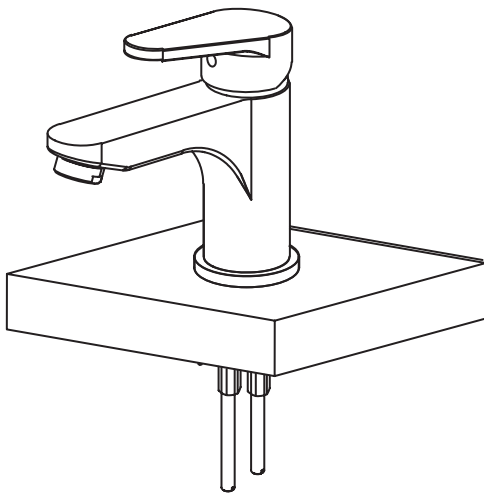

Installare il lavabo miscelatore nel centro del foro creato.

Install basin through center hole.

STEP 3

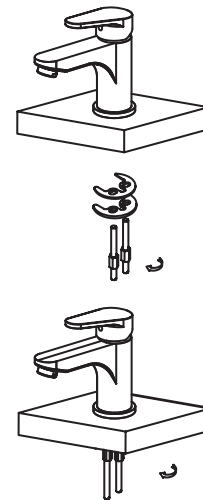

Installare la mezzaluna in fibra seguita dalla mezzaluna metallica. Ultimare il serraggio tramite i tiranti e i dadi presenti nella confezione.

Install the fiber halfmoon followed by the metallic halfmoon. Complete the tightening using the tie rods and the nuts included in the package.



STEP 4

Avvitare e stringere a mano i tubi flessibili del caldo e del freddo al lavabo miscelatore. Non usare una chiave per stringere i tubi per non danneggiare il tubo e/o le filettature del tubo.

Screw and hand tighten the hot and cold flexible hoses to the basin inlet tubes. Do not use a wrench to tighten hoses as this may damage the hose and/or the hose's threads.

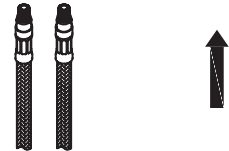
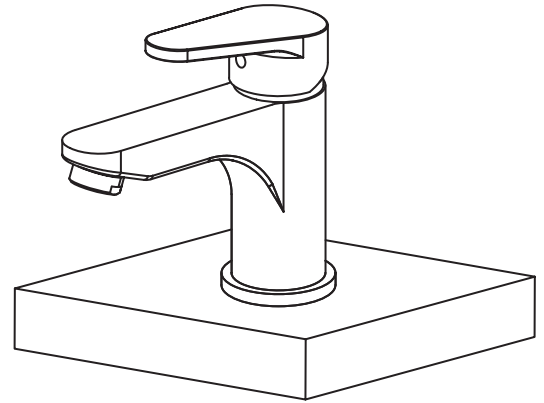

STEP 5

Collegare il tubo flessibile alla rete idrica.

Connect flexible hose to water supply.

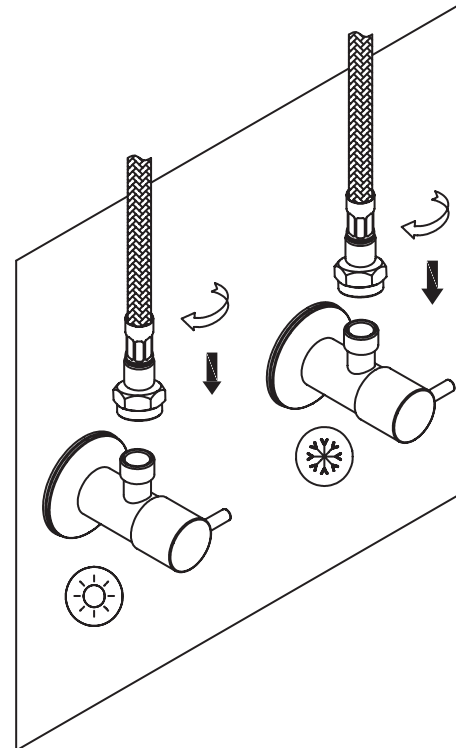



STEP 6

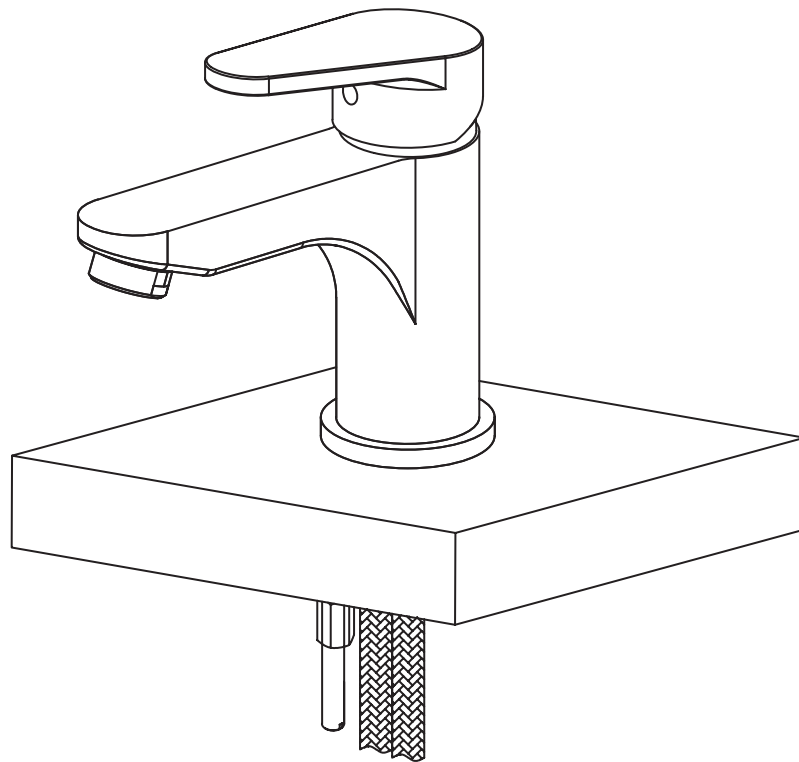

Rimuovere l'aeratore e aprire il miscelatore del rubinetto per circa 1 minuto per togliere eventuali detriti dal miscelatore e dalle linee di alimentazione. Girare il miscelatore del rubinetto del lavabo chiudere l'acqua e reinstallare l'aeratore.

Remove the aerator and turn off tap mixer for 1-minute to flush debris from basin and feed lines. Turn off tap mixer and re-install aerator.



Aeratore limitato

Limited aerator

| Misurazione (Measure) | Pressione (Pressure) (bar) | Portata Calda (Hot Flow Rate) (l/min) | Portata Fredda (Cold Flow Rate) (l/min) | Portata Miscelata (Mix Flow Rate) (l/min) |
|--------------------------|----------------------------------|---|---|---|
| 1 | 0 | 0,00 | 0,00 | 0,00 |
| 2 | 0,5 | 3,44 | 3,67 | 4,02 |
| 3 | 1 | 4,42 | 4,54 | 4,71 |
| 4 | 1,5 | 5,26 | 5,52 | 5,50 |
| 5 | 2 | 5,80 | 5,95 | 5,93 |
| 6 | 2,5 | 6,11 | 6,22 | 6,02 |
| 7 | 3 | 6,22 | 6,27 | 6,22 |
| 8 | 3,5 | 6,42 | 6,48 | 6,39 |
| 9 | 4 | 6,51 | 6,65 | 6,51 |
| 10 | 4,5 | 6,65 | 6,77 | 6,65 |
| 11 | 5 | 6,72 | 6,82 | 6,74 |
| 12 | 5,5 | 6,83 | 6,91 | 6,91 |
| 13 | 6 | 6,99 | 7,00 | 6,95 |

Massima Pressione Operativa (MPO): 5 bar
Maximum Operating Pressure (MOP): 5 bar

Test eseguito con flessibili originali
(Test performed with original hoses)

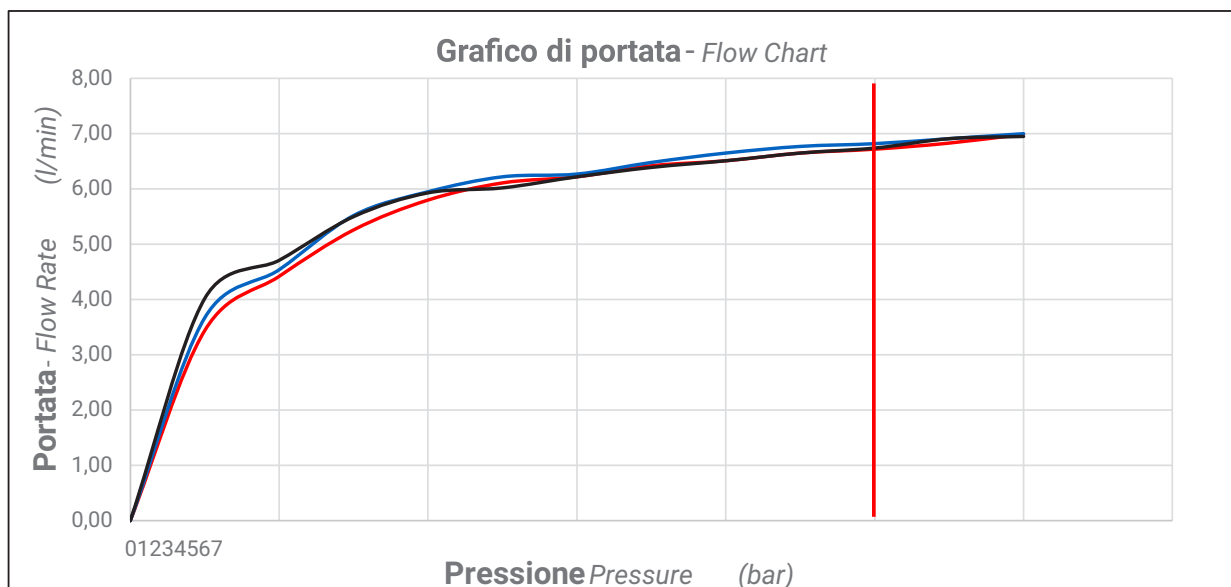

Non superare la pressione di 5 bar (linea rossa)

Do not exceed the pressure of 5 bar (red line)



Aeratore non limitato

Not limited aerator

| Misurazione (Measure) | Pressione (Pressure) (bar) | Portata Calda (Hot Flow Rate) (l/min) | Portata Fredda (Cold Flow Rate) (l/min) | Portata Miscelata (Mix Flow Rate) (l/min) |
|--------------------------|----------------------------------|---|---|---|
| 1 | 0 | 0,00 | 0,00 | 0,00 |
| 2 | 0,5 | 4,71 | 4,74 | 5,24 |
| 3 | 1 | 5,61 | 5,70 | 6,25 |
| 4 | 1,5 | 6,81 | 6,97 | 7,61 |
| 5 | 2 | 7,98 | 7,96 | 8,85 |
| 6 | 2,5 | 8,91 | 8,94 | 9,84 |
| 7 | 3 | 9,78 | 9,75 | 10,88 |
| 8 | 3,5 | 10,61 | 10,62 | 11,66 |
| 9 | 4 | 11,32 | 11,37 | 12,65 |
| 10 | 4,5 | 12,07 | 12,11 | 13,26 |
| 11 | 5 | 12,82 | 12,73 | 14,02 |
| 12 | 5,5 | 13,42 | 13,37 | 14,77 |
| 13 | 6 | 14,05 | 14,12 | 15,42 |

Massima Pressione Operativa (MPO): 5 bar
 Maximum Operating Pressure (MOP): 5 bar

Test eseguito con flessibili originali
 (Test performed with original hoses)

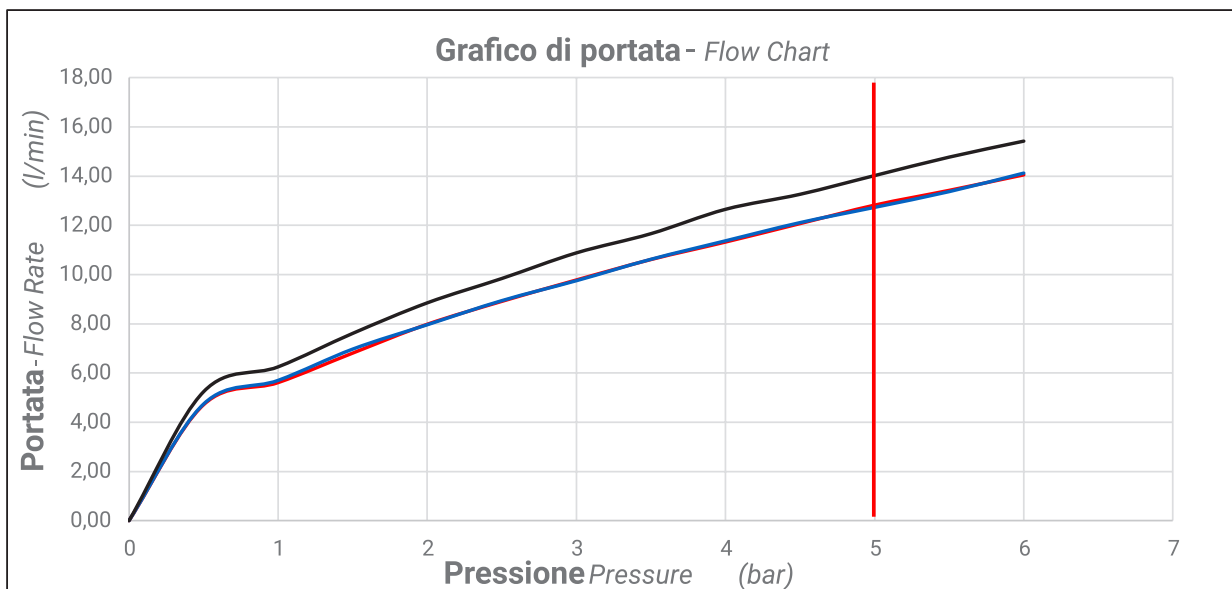

Non superare la pressione di 5 bar (linea rossa)
 Do not exceed the pressure of 5 bar (red line)



Non utilizzare, per la pulizia, in nessun caso acidi, solventi, candeggina, ammoniaca o prodotti contenenti acidi e spugne o spazzole con effetto abrasivo.

Never use acids, solvents, bleach, ammonia or products containing acids and sponges or brushes with an abrasive effect for cleaning.



Per un corretto mantenimento dei prodotti si consiglia una pulizia periodica attraverso detergenti neutri o acqua e sapone.

For correct maintenance of the products, periodic cleaning is recommended using neutral detergents or soap and water.



Per evitare la formazione di depositi calcarei sciacquare sempre le superfici dopo lavaggio con abbondante acqua e asciugare accuratamente con un panno morbido.

To avoid the formation of limescale deposits, always rinse the surfaces after washing with plenty of water and dry carefully with a soft cloth.



Per un corretto mantenimento del getto di acqua pulire periodicamente l'aeratore immergendolo, dopo averlo smontato in soluzione di acqua e aceto.

For correct maintenance of the water jet, periodically clean the aerator by immersing it, after having disassembled it, in a solution of water and vinegar.