

Manuale d'installazione
Installation Manual

SOG
S E R I E S

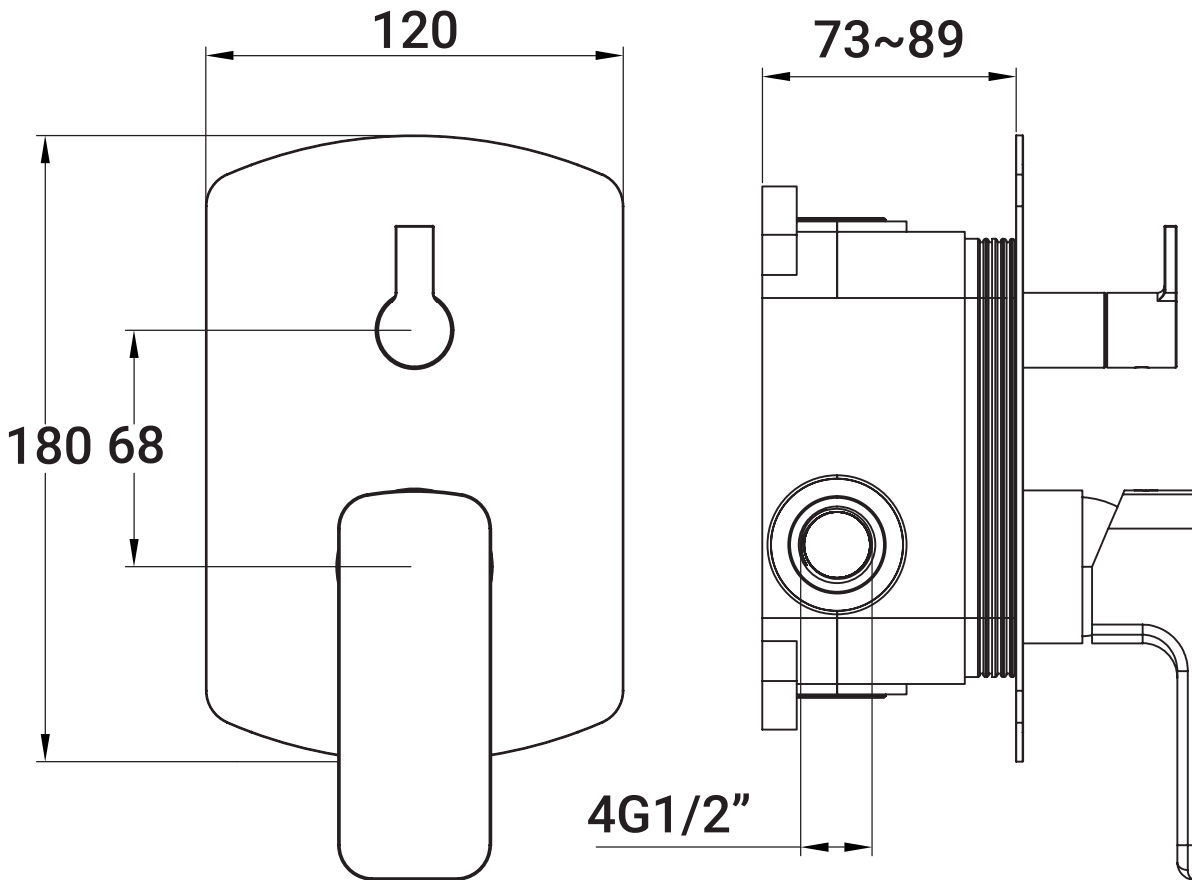

Incasso doccia
Concealed shower





Nr.	Descrizione Description	Codice Code
01	Cartuccia Cartridge	CA0003

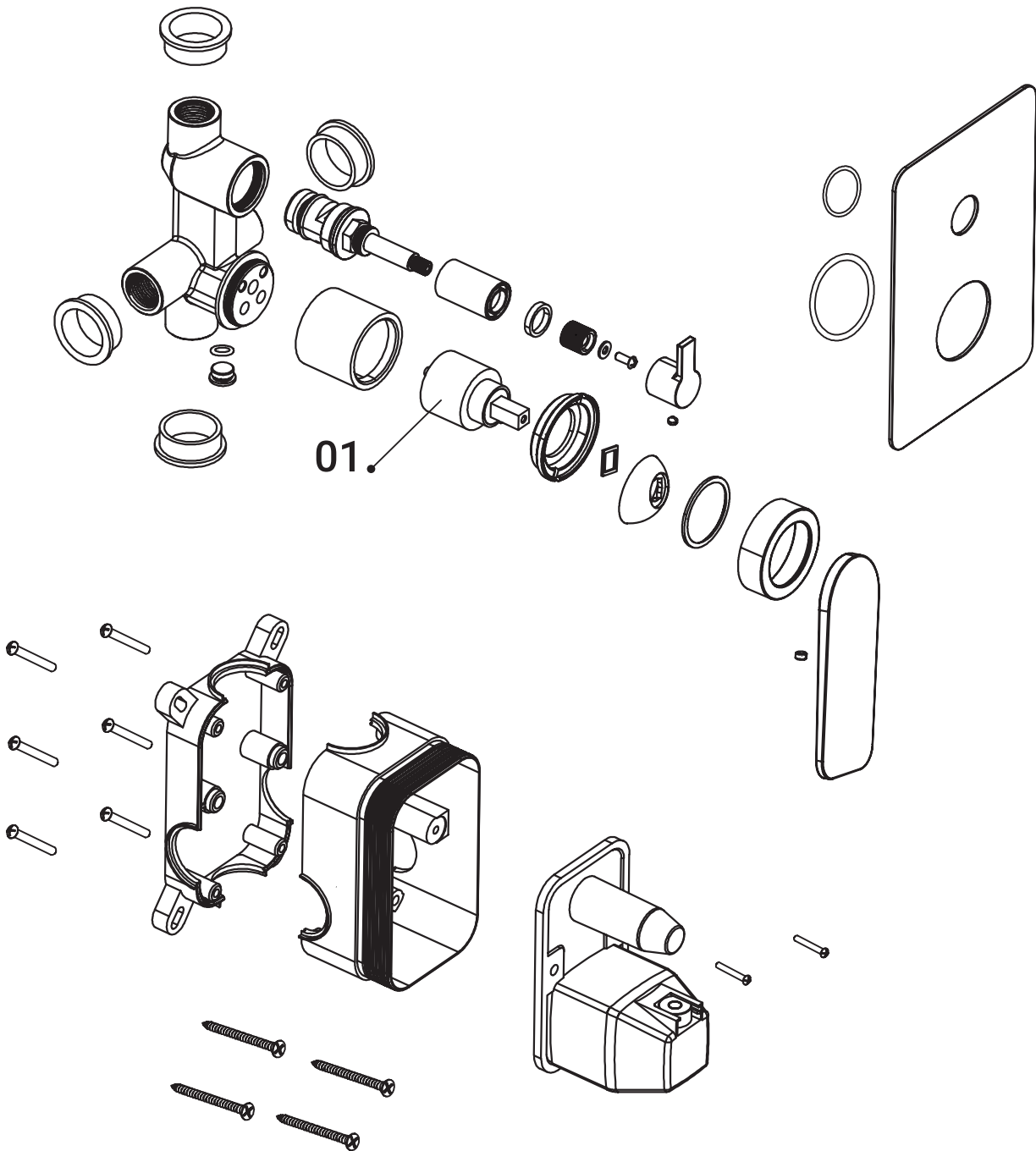



Prima dell'installazione Before Installation



Rimuovi tutto il contenuto dalla confezione e verificane la completezza.

Remove all contents from the package and check for completeness.

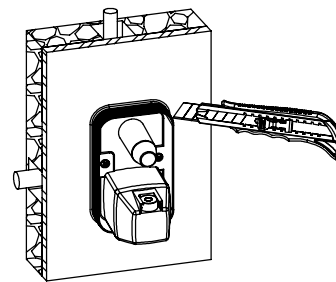
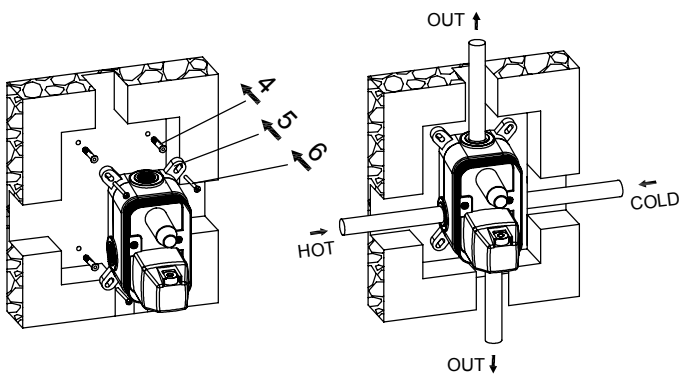
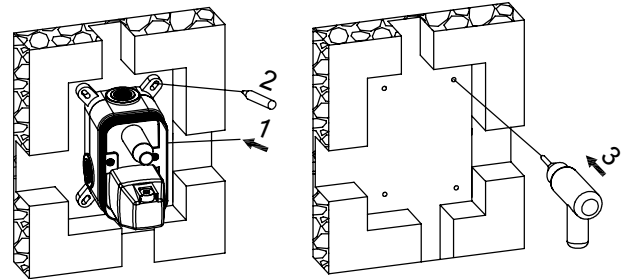

Taglia il guscio di plastica
Cutting plastic shell

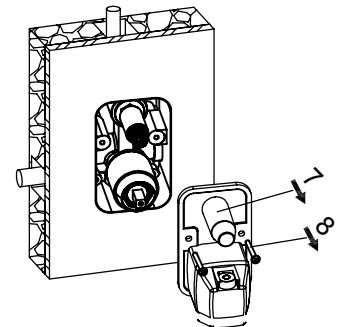

Strumenti necessari Tools you need

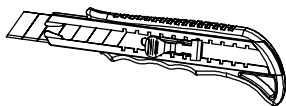

Taglierino
Cutter

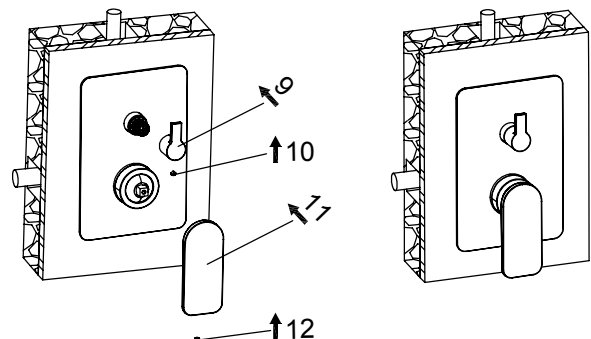



Misurazione (Measure)	Pressione (Pressure) (bar)	Portata Calda Soffione (Hot Flow Rate) (l/min)	Portata Fredda Soffione (Cold Flow Rate) (l/min)	Portata Miscelata Soffione (Mix Flow Rate) (l/min)
1	0	0,00	0,00	0,00
2	0,5	6,86	6,42	6,25
3	1	8,94	8,28	8,13
4	1,5	10,45	9,75	9,55
5	2	11,82	11,14	11,02
6	2,5	13,05	12,33	12,15
7	3	14,12	13,31	13,25
8	3,5	15,21	14,41	14,21
9	4	16,12	15,43	15,22
10	4,5	17,05	16,51	16,12
11	5	17,77	17,32	17,05
12	5,5	18,55	18,05	17,98
13	6	19,03	18,52	18,45

Massima Pressione Operativa (MPO): 5 bar
Maximum Operating Pressure (MOP): 5 bar

Test eseguito con connessioni originali
(Test performed with original connections)

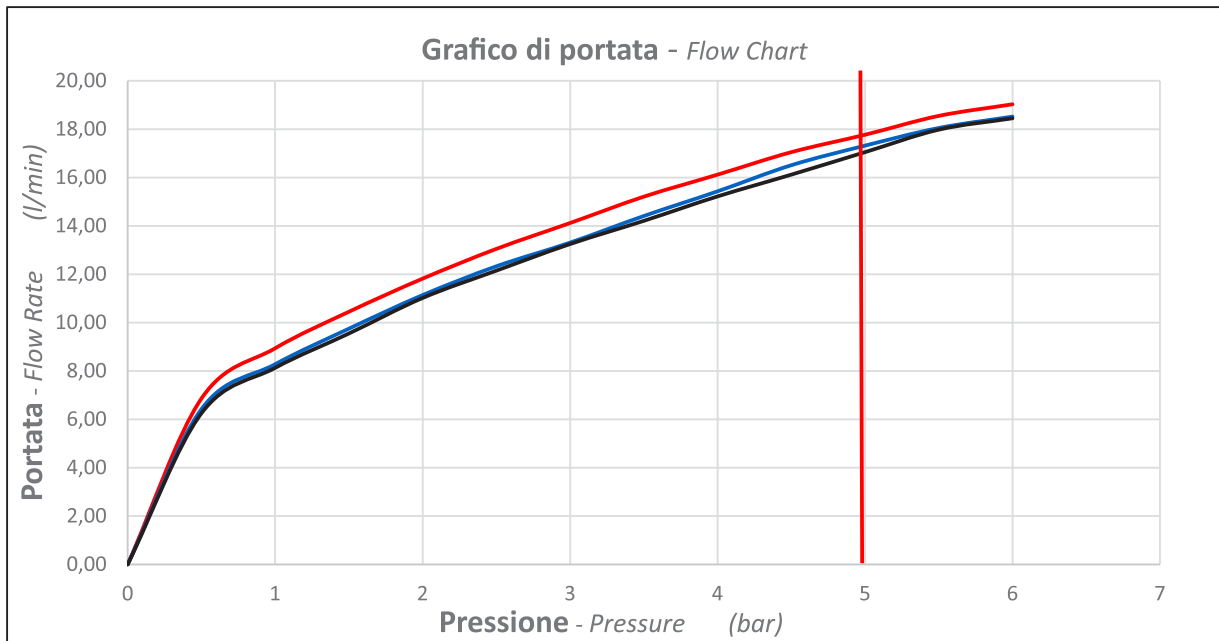

Non superare la pressione di 5 bar (linea rossa)
Do not exceed the pressure of 5 bar (red line)

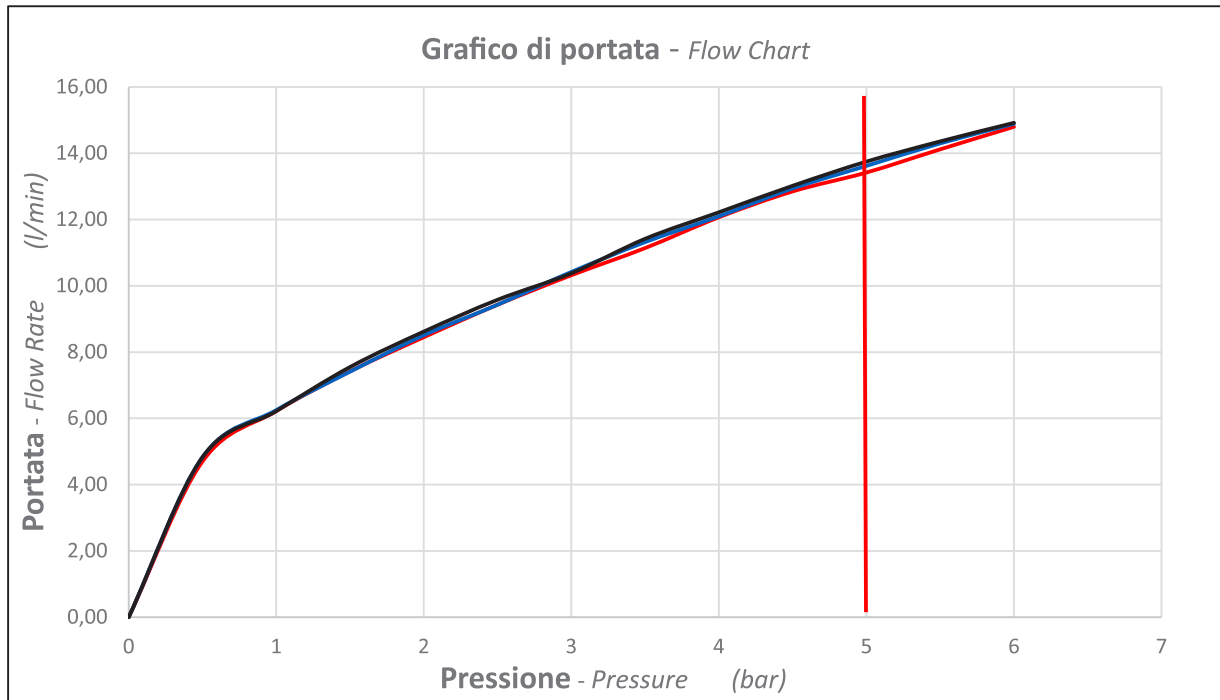

Misurazione (Measure)	Pressione (Pressure) (bar)	Portata Calda Doccetta (Hot hand shower Flow Rate) (l/min)	Portata Fredda Doccetta (Cold Flow hand shower Rate) (l/min)	Portata Miscelata Doccetta (Mix hand shower Flow Rate) (l/min)
1	0	0,00	0,00	0,00
2	0,5	4,70	4,83	4,83
3	1	6,22	6,25	6,22
4	1,5	7,42	7,41	7,55
5	2	8,45	8,51	8,62
6	2,5	9,43	9,43	9,58
7	3	10,32	10,42	10,38
8	3,5	11,14	11,32	11,42
9	4	12,07	12,10	12,22
10	4,5	12,85	12,94	13,02
11	5	13,42	13,62	13,75
12	5,5	14,12	14,30	14,36
13	6	14,80	14,89	14,92

Massima Pressione Operativa (MPO): 5 bar
Maximum Operating Pressure (MOP): 5 bar
Test eseguito con connessioni originali
(Test performed with original connections)

Non superare la pressione di 5 bar (linea rossa)
Do not exceed the pressure of 5 bar (red line)



Non utilizzare, per la pulizia, in nessun caso acidi, solventi, candeggina, ammoniaca o prodotti contenenti acidi e spugne o spazzole con effetto abrasivo.

Never use acids, solvents, bleach, ammonia or products containing acids and sponges or brushes with an abrasive effect for cleaning.



Per un corretto mantenimento dei prodotti si consiglia una pulizia periodica attraverso detergenti neutri o acqua e sapone.

For correct maintenance of the products, periodic cleaning is recommended using neutral detergents or soap and water.



Per evitare la formazione di depositi calcarei sciacquare sempre le superfici dopo lavaggio con abbondante acqua e asciugare accuratamente con un panno morbido.

To avoid the formation of limescale deposits, always rinse the surfaces after washing with plenty of water and dry carefully with a soft cloth.



Per un corretto mantenimento del getto di acqua pulire periodicamente l'aeratore immergendolo, dopo averlo smontato in soluzione di acqua e aceto.

For correct maintenance of the water jet, periodically clean the aerator by immersing it, after having disassembled it, in a solution of water and vinegar.